

Exploring Compressed Supersymmetry at the LHC

Stephen P. Martin
Northern Illinois University

Miami 2008
December 20, 2008

hep-ph/0703097, 0707.2812, 0801.0237, 0807.2820

Outline:

- What is “Compressed SUSY”?
- Same-sign tops + missing energy signal
- Stoponium!?

Supersymmetry is a symmetry that relates fermions and bosons:

$$Q|\text{fermion}\rangle = |\text{boson}\rangle \quad Q|\text{boson}\rangle = |\text{fermion}\rangle.$$

This eliminates the quadratic sensitivity of the electroweak scale to high mass scales like the Planck scale.

The penalty/reward is that the number of particles is doubled.

Names	Spin	P_R	Mass Eigenstates	Gauge Eigenstates
Higgs bosons	0	+1	$h^0 \ H^0 \ A^0 \ H^\pm$	$H_u^0 \ H_d^0 \ H_u^\pm \ H_d^\mp$
squarks	0	-1	$\tilde{u}_L \ \tilde{u}_R \ \tilde{d}_L \ \tilde{d}_R$	“ ”
			$\tilde{s}_L \ \tilde{s}_R \ \tilde{c}_L \ \tilde{c}_R$	“ ”
			$\tilde{t}_1 \ \tilde{t}_2 \ \tilde{b}_1 \ \tilde{b}_2$	$\tilde{t}_L \ \tilde{t}_R \ \tilde{b}_L \ \tilde{b}_R$
sleptons	0	-1	$\tilde{e}_L \ \tilde{e}_R \ \tilde{\nu}_e$	“ ”
			$\tilde{\mu}_L \ \tilde{\mu}_R \ \tilde{\nu}_\mu$	“ ”
			$\tilde{\tau}_1 \ \tilde{\tau}_2 \ \tilde{\nu}_\tau$	$\tilde{\tau}_L \ \tilde{\tau}_R \ \tilde{\nu}_\tau$
neutralinos	1/2	-1	$\tilde{N}_1 \ \tilde{N}_2 \ \tilde{N}_3 \ \tilde{N}_4$	$\tilde{B}^0 \ \tilde{W}^0 \ \tilde{H}_u^0 \ \tilde{H}_d^0$
charginos	1/2	-1	$\tilde{C}_1^\pm \ \tilde{C}_2^\pm$	$\tilde{W}^\pm \ \tilde{H}_u^\pm \ \tilde{H}_d^\mp$
gluino	1/2	-1	\tilde{g}	“ ”

Most important in the following: the neutral LSP (\tilde{N}_1) = dark matter, the lighter top squark (\tilde{t}_1), and the color-octet gluino \tilde{g} .

The gaugino mass parameters M_1, M_2, M_3
(for $U(1)_Y, SU(2)_L$, and $SU(3)_c$, respectively)
have a strong effect on the masses of all superpartners.

In the most popular class of models, mSUGRA, one assumes that

$$M_1 = M_2 = M_3 \equiv m_{1/2}$$

as running parameters near the Planck scale.

Here's the typical renormalization group running of sparticle masses
that results:

Taking mSUGRA near the GUT scale predicts a hierarchical mass spectrum at the TeV scale:

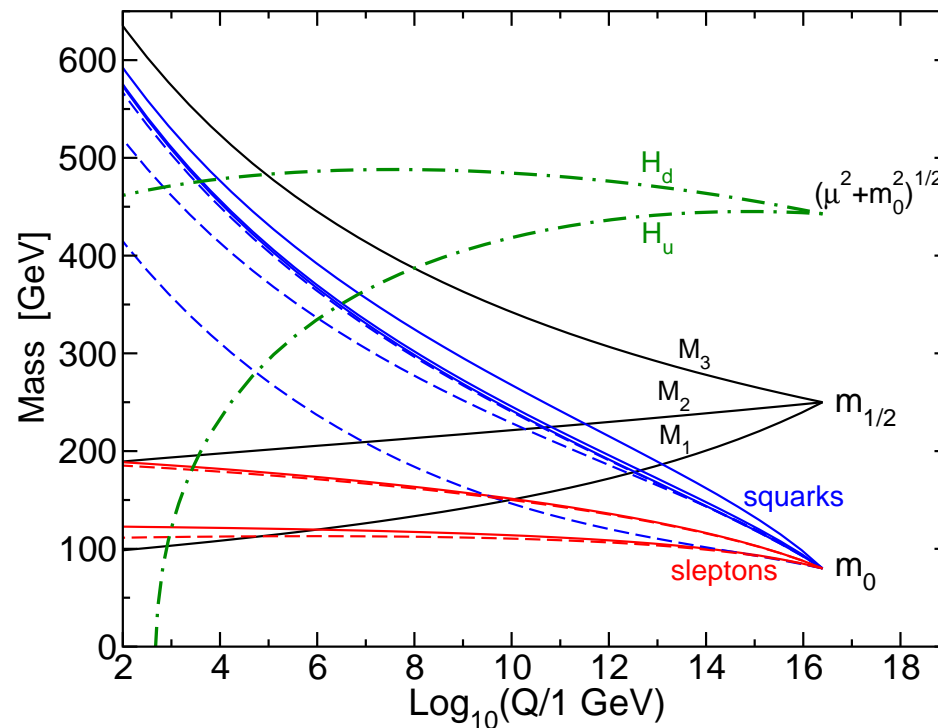

This hierarchy is mostly the fault of the gluino mass (M_3).

“Compressed supersymmetry” is an alternative leading to a smaller hierarchy of superpartner masses.

The mSUGRA assumption is equivalent to the statement that the source of spontaneous breaking of SUSY is a VEV

$$\langle F \rangle \neq 0$$

that is a **singlet** under the unified gauge group.

But, more generally, F could transform as any representation in the symmetric product of the adjoint representation of the gauge group with itself, as long as the result contains a Standard Model singlet.

For $SU(5)$:

$$(24 \times 24)_S = 1 + 24 + 75 + 200$$

If the F terms that break SUSY include both a singlet and an adjoint of $SU(5)$, then at the GUT scale, one can parametrize:

$$\begin{aligned}M_1 &= m_{1/2}(1 + C_{24}), \\M_2 &= m_{1/2}(1 + 3C_{24}), \\M_3 &= m_{1/2}(1 - 2C_{24}).\end{aligned}$$

The special case $C_{24} = 0$ recovers the usual mSUGRA model.

“Compressed supersymmetry” is the assumption that $M_3/M_2 \sim 1/3$, which follows if $C_{24} \sim 0.2$.

Compressed SUSY: the gluino mass parameter M_3 is taken much smaller than the wino mass parameter M_2 near the GUT scale.

- Ratio of heaviest to lightest superpartner masses is reduced compared to mSUGRA.
- Lessens the SUSY little hierarchy problem
- Naturally allows the correct dark matter thermal relic abundance $0.09 < \Omega_{\text{CDM}} h^2 < 0.13$ by top-squark-mediated LSP annihilation in the early universe: $\tilde{N}_1 \tilde{N}_1 \rightarrow t\bar{t}$.

Compressed supersymmetry is unique in that dark matter annihilation in the early universe proceeds through top squark exchange.

Diagrams leading to $\tilde{N}_1 \tilde{N}_1 \rightarrow t \bar{t}$:

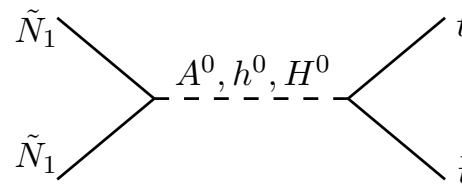
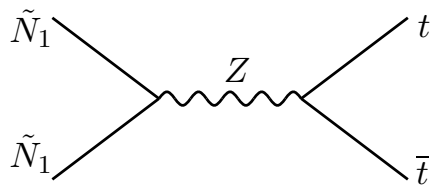
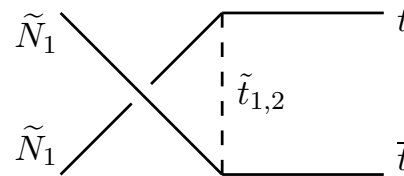
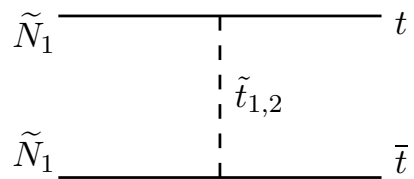

The \tilde{t}_1 exchange dominates.

Note no p -wave suppression because of large m_t .

To get $\Omega_{\text{DM}} h^2$ into the WMAP-allowed range, need roughly:

$$m_t < m_{\tilde{N}_1} \lesssim m_t + 100 \text{ GeV},$$

$$m_{\tilde{N}_1} + 25 \text{ GeV} \lesssim m_{\tilde{t}_1} \lesssim m_{\tilde{N}_1} + 100 \text{ GeV}.$$

Allowed regions in the $m_{\tilde{t}_1}, m_{\tilde{N}_1}$ plane for $C_{24} = 0.21$:

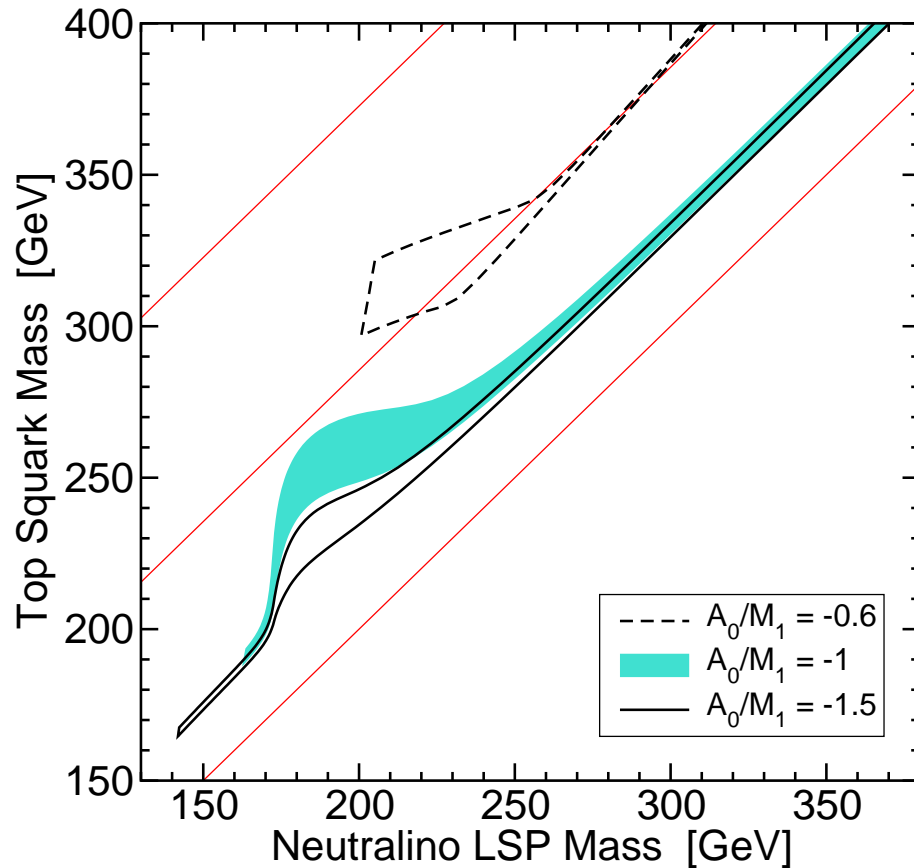

In the bulge regions,
 $\tilde{N}_1 \tilde{N}_1 \rightarrow t\bar{t}$ is mediated mostly
 by \tilde{t}_1 exchange.

Below upper red line, $\tilde{t}_1 \rightarrow t\tilde{N}_1$
 is forbidden.

Below middle red line,
 $\tilde{t}_1 \rightarrow Wb\tilde{N}_1$ is also forbidden.

Below lowest red line, \tilde{t}_1 is LSP.

Regions are cut off on the left by the M_h constraint.

Thin regions on either side of the bulge obtain correct dark matter density by
 co-annihilation with top-squark .

A typical Compressed SUSY mass spectrum:

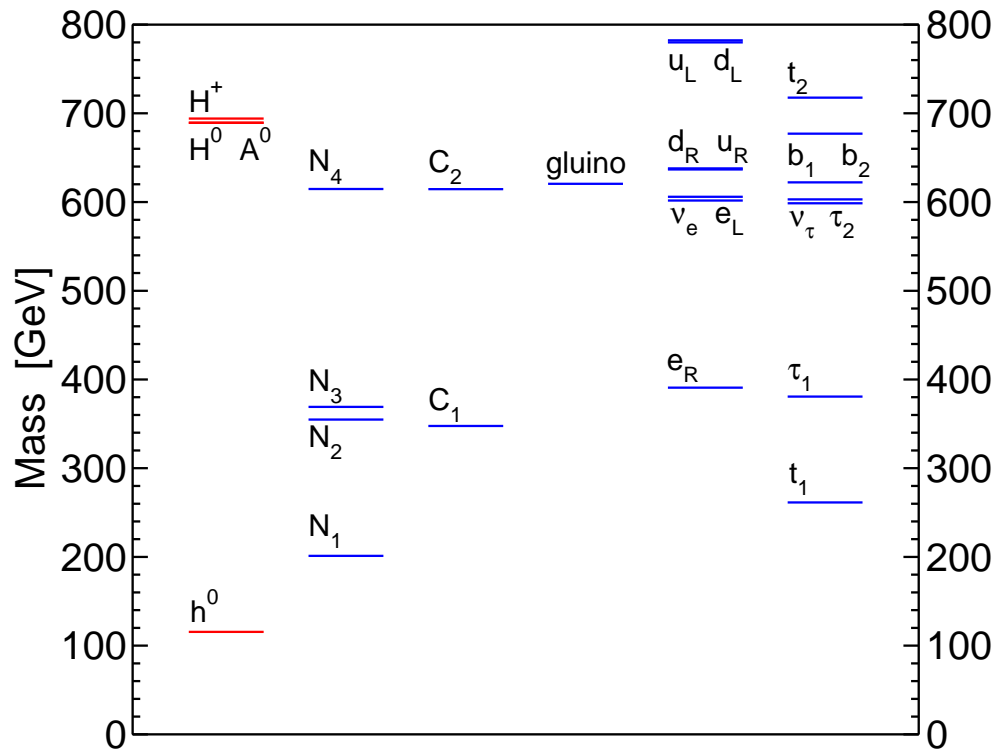

Important decays for hadron colliders:

$$\tilde{t}_1 \rightarrow c\tilde{N}_1 \quad (100\%)$$

$$\tilde{g} \rightarrow \begin{cases} t\tilde{t}_1^* & (\sim 50\%) \\ \bar{t}\tilde{t}_1 & (\sim 50\%) \end{cases}$$

$$\tilde{q}_L \rightarrow \begin{cases} q\tilde{g} & (\sim 80\%) \\ q'\tilde{C}_2 & (\sim 10\%) \end{cases}$$

$$\tilde{q}_R \rightarrow q\tilde{N}_1 \quad (\sim 90\%)$$

Distinctive features of Compressed SUSY:

- Ratio of heaviest to lightest superpartner masses is < 4 .
- \tilde{t}_1 is light, cannot decay to $t\tilde{N}_1$ in this scenario.
- Weakly-interacting superpartners are hard to see at hadron colliders.

Total SUSY production rates at the 14 TeV LHC:

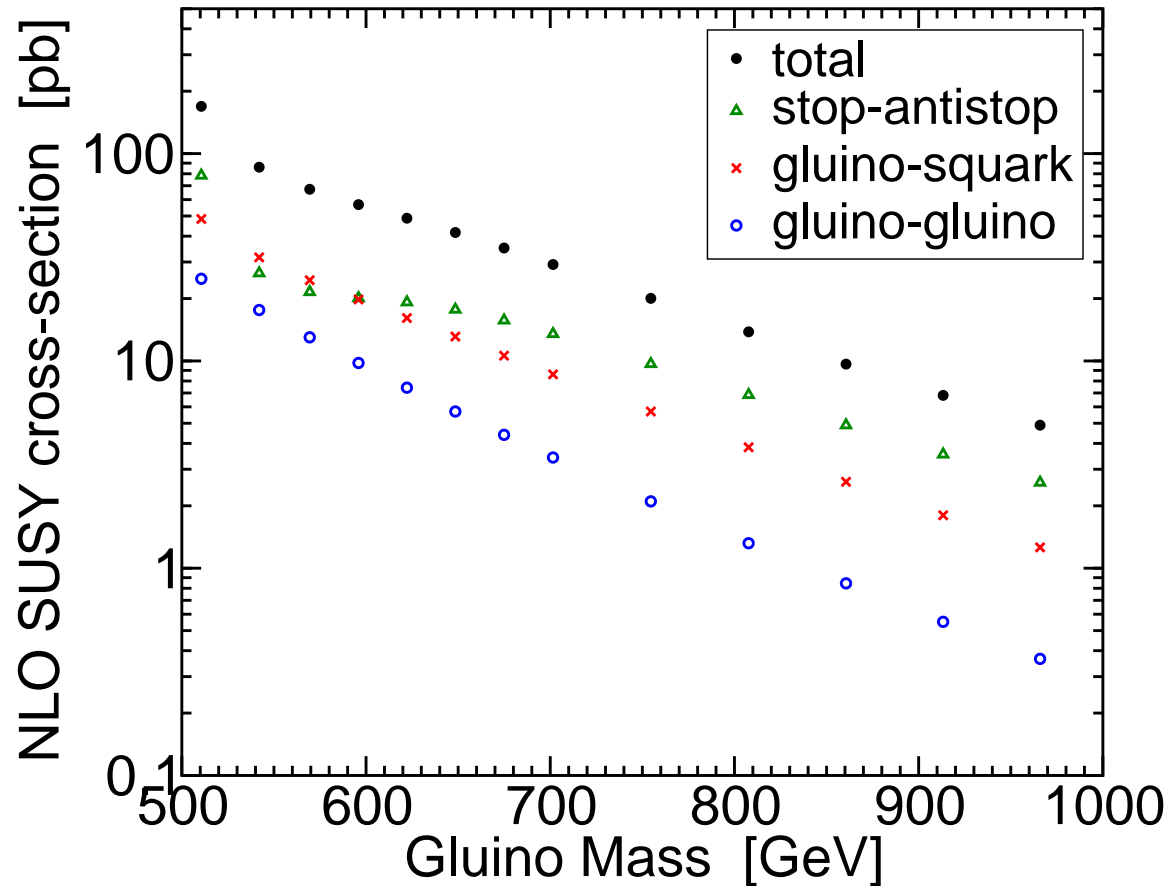

Early discovery with jets + E_T^{miss} should be easy.

But then what?

Compressed SUSY presents some challenges for LHC:

- Direct top-squark pair production is a tough signal
- Sleptons, winos, higgsinos nearly decouple from LHC
- No dilepton mass edges
- Few isolated leptons except from top decays

A clean and distinctive LHC signal:

$$pp \rightarrow \tilde{g}\tilde{g} \rightarrow \begin{cases} t\bar{t}\tilde{t}_1\tilde{t}_1^* \rightarrow t\bar{t}c\bar{c} + E_T^{\text{miss}} & (50\%) \\ tt\tilde{t}_1^*\tilde{t}_1^* \rightarrow tt\bar{c}\bar{c} + E_T^{\text{miss}} & (25\%) \\ \bar{t}\bar{t}\tilde{t}_1\tilde{t}_1 \rightarrow \bar{t}\bar{t}cc + E_T^{\text{miss}} & (25\%) \end{cases}$$

Due to the Majorana gluino, get Same-Sign dileptons, two b jets, and other jets from the top-squark decays:

$$\begin{aligned} & \ell^+\ell^+bb + \text{jets} + E_T^{\text{miss}}, \\ & \ell^-\ell^-bb + \text{jets} + E_T^{\text{miss}} \end{aligned}$$

Use MadGraph/MadEvent \rightarrow Pythia \rightarrow PGS4 for event generation and detector simulation.

Require:

- Exactly 2 Same-Sign isolated leptons ($\ell = e, \mu$) with $p_T > 20$ GeV
- At least two b -tagged jets each with $p_T > 50$ GeV
- At least two more jets with $p_T > 50, 35$ GeV
- Two Same-Sign lepton- b pair assignments, each consistent with leptonic top decay: $M(\ell b) < 160$ GeV
- $E_T^{\text{miss}} > 100$ GeV

With these cuts, the Standard Model background is mostly $t\bar{t}$: less than 1 event/fb $^{-1}$. (Kraml and Raklev hep-ph/0512284.)

Signal rates, after cuts, for $\ell^\pm \ell^\pm b b j j + E_T^{\text{miss}}$

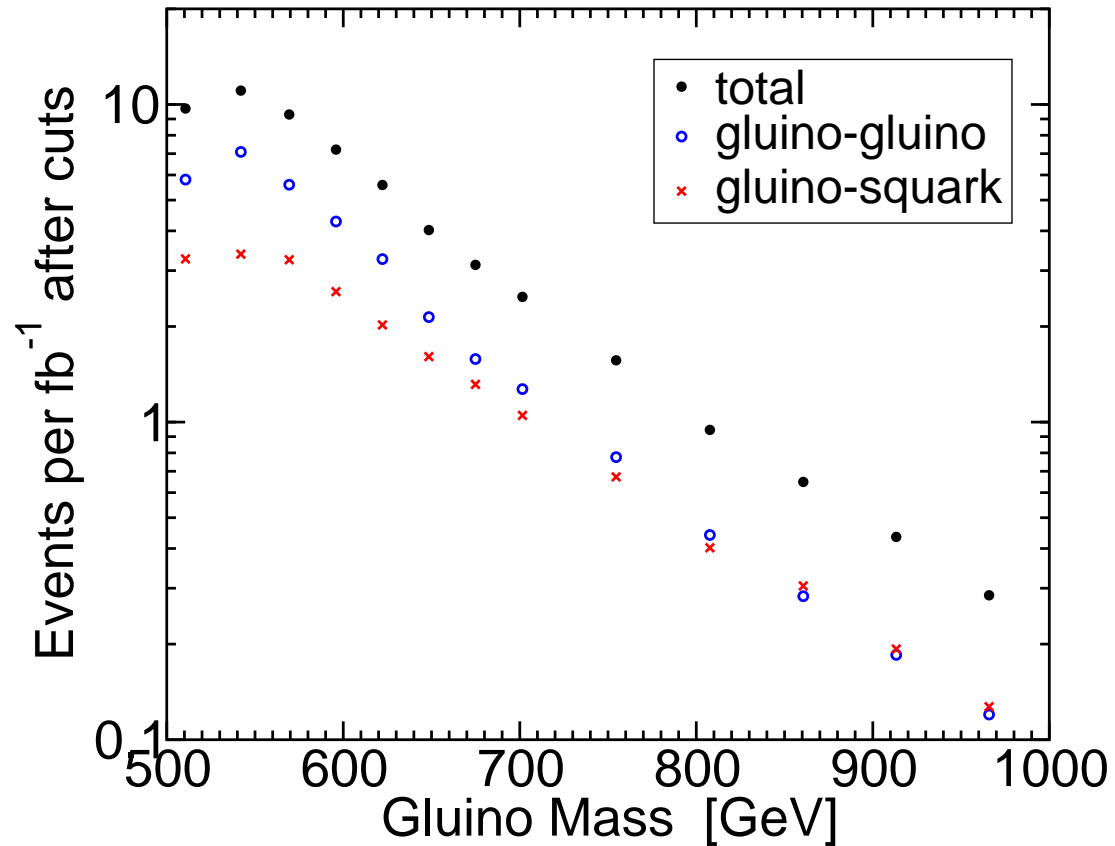

Detection prospects will depend on how well Same-Sign lepton backgrounds can be understood.

Consider a mass estimator (similar to M_{eff}):

$$M_B = \sum_{n=1,2,3,4} p_T(j_n) + \sum_n p_T(\ell_n) + E_T^{\text{miss}}$$

Since the production is dominated by gluino-gluino and gluino-squark, this should be correlated with the gluino mass.

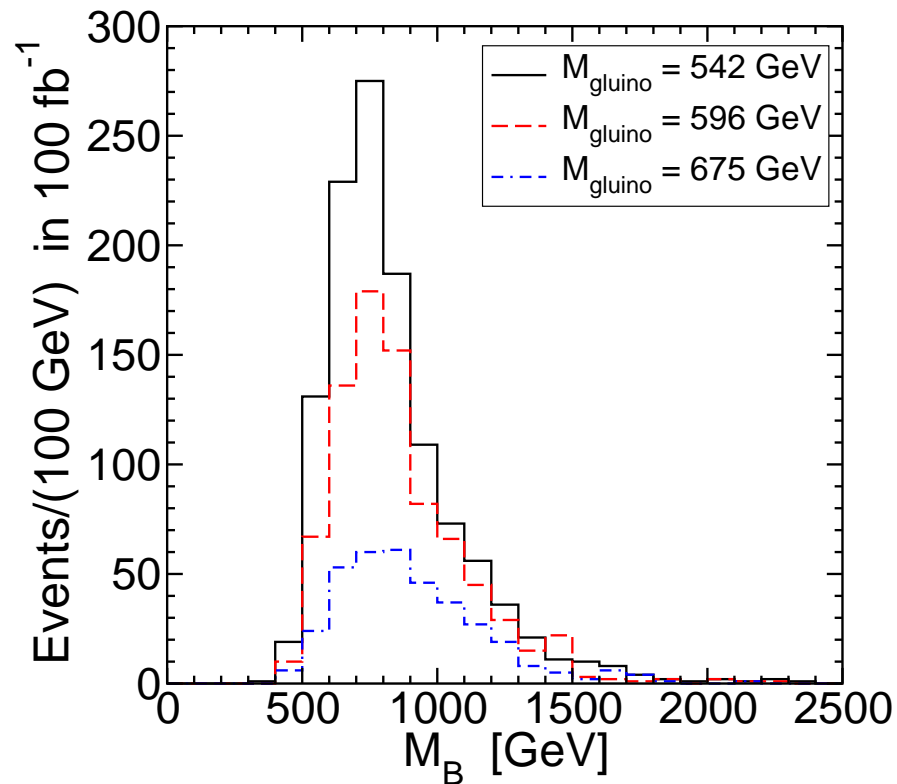

From fits to 100 fb^{-1} of data for various gluino masses:

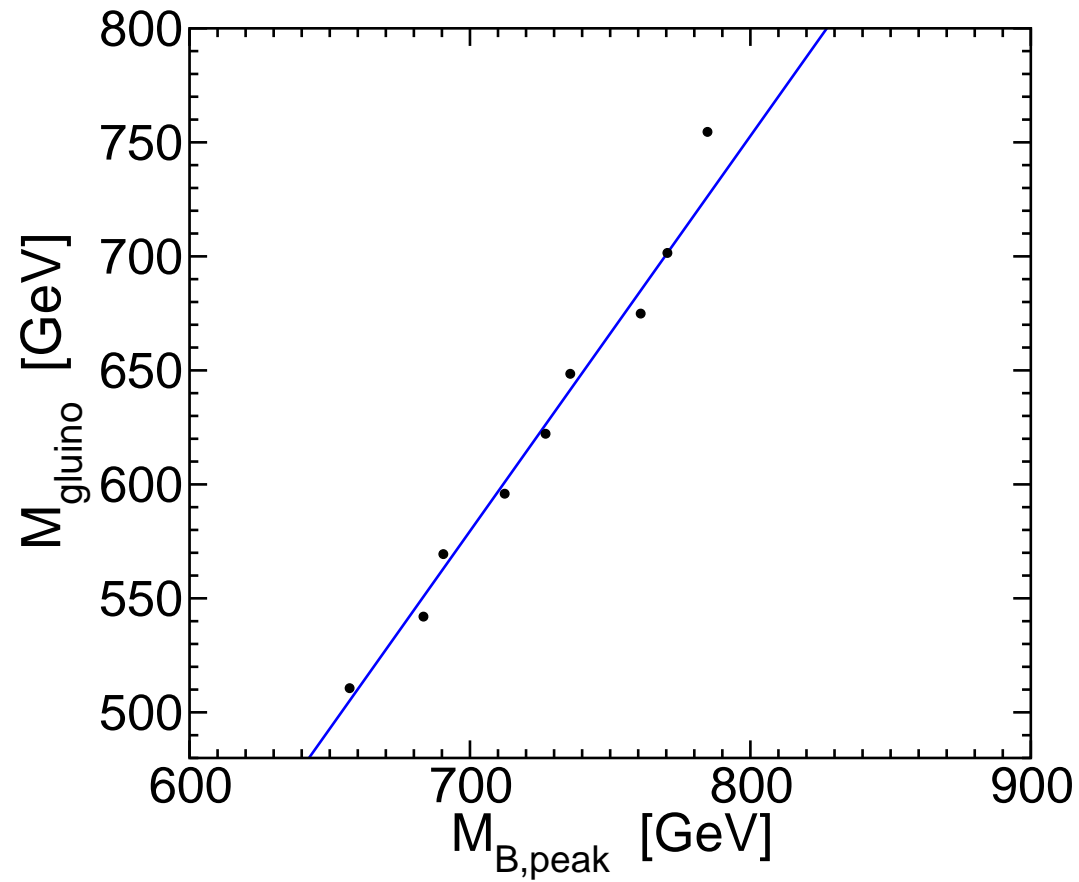

$$M_{\tilde{g}} = 1.73 M_{B,\text{peak}} - 630 \text{ GeV}$$

Look at the mass endpoints of visible decay products of the gluino: b, l, c .

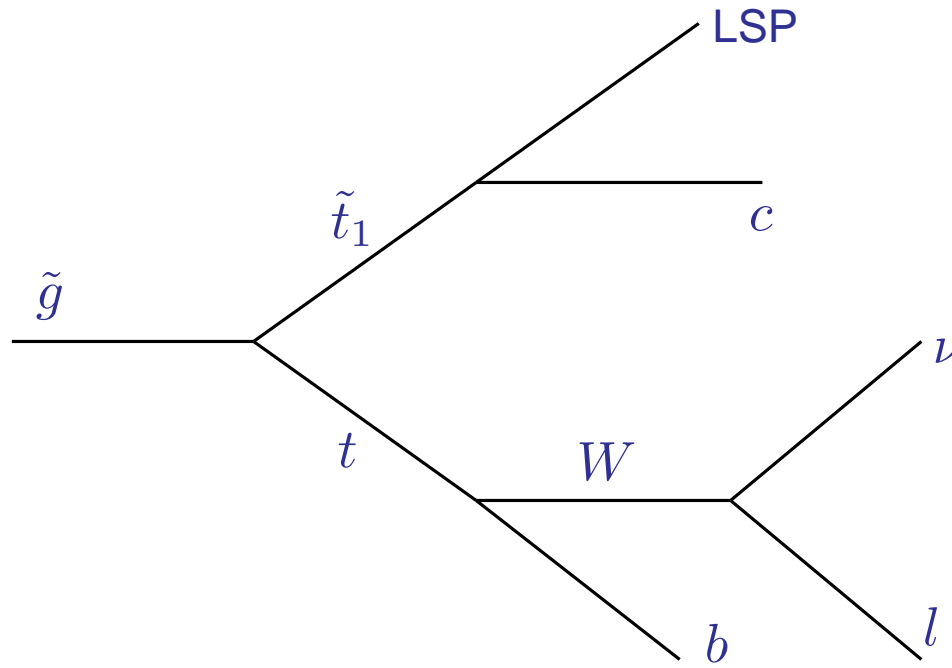

The top decay has:

$$M^2(bl)_{\max} = m_t^2 - m_W^2 \approx (153 \text{ GeV})^2.$$

No new information on masses, but allows b jets to be paired with leptons.

The theoretical shapes of the $M(lc)$, $M(bc)$, and $M(blc)$ distributions:

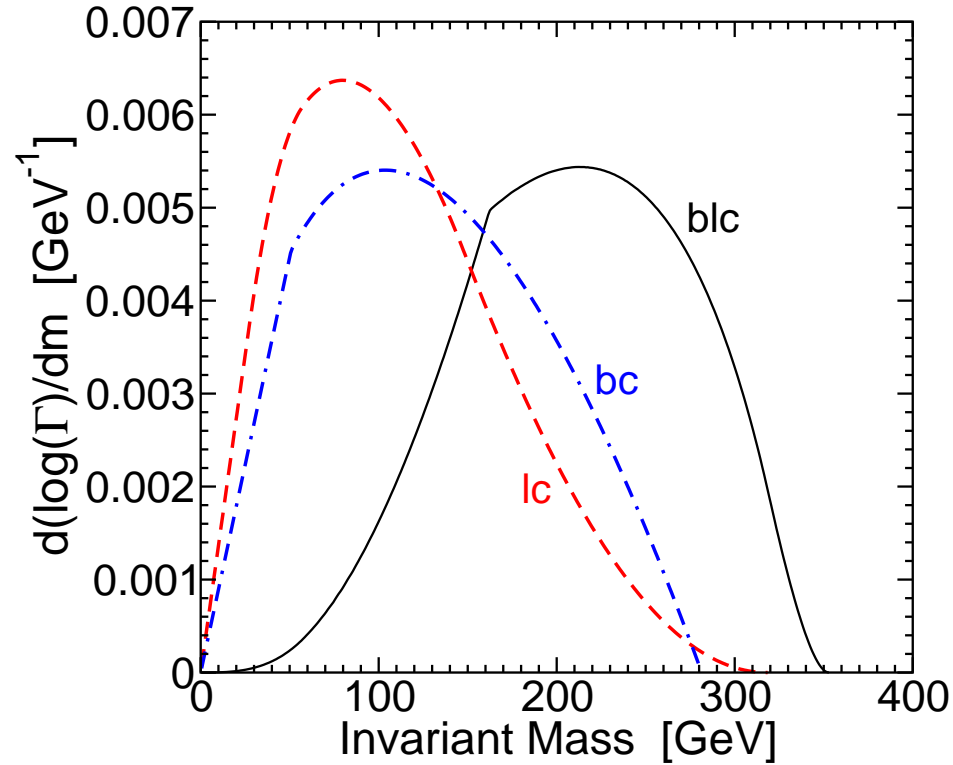

This is for $m_{\tilde{g}} = 596$, $m_{\tilde{t}_1} = 261$, and $m_{\tilde{N}_1} = 201$ GeV.

Endpoints are $m(lc)_{\max} = 320$, $m(bc)_{\max} = 283$, $m(blc)_{\max} = 354$ GeV.

Unfortunately, the $M(lc)$ distribution is very shallow near the endpoint, so concentrate on the other two.

To get as clean a sample as possible:

Select events with same cuts as before, and a **unique** pairing of b -jets with leptons so that both pairs have $M(bl) < 180$ GeV.

For each (bl) pair, choose the jet with the smallest $M(bl_c)$ as the charm jet candidate. Require $p_T(j_c) > 35$ GeV.

Look for the endpoints in both $M(bl_c)$ and $M(bc)$.

For 100 fb^{-1} , and a model with $M_{\text{gluino}} = 569 \text{ GeV}$, with a nominal endpoint $M(\text{blc})_{\text{max}} = 350 \text{ GeV}$:

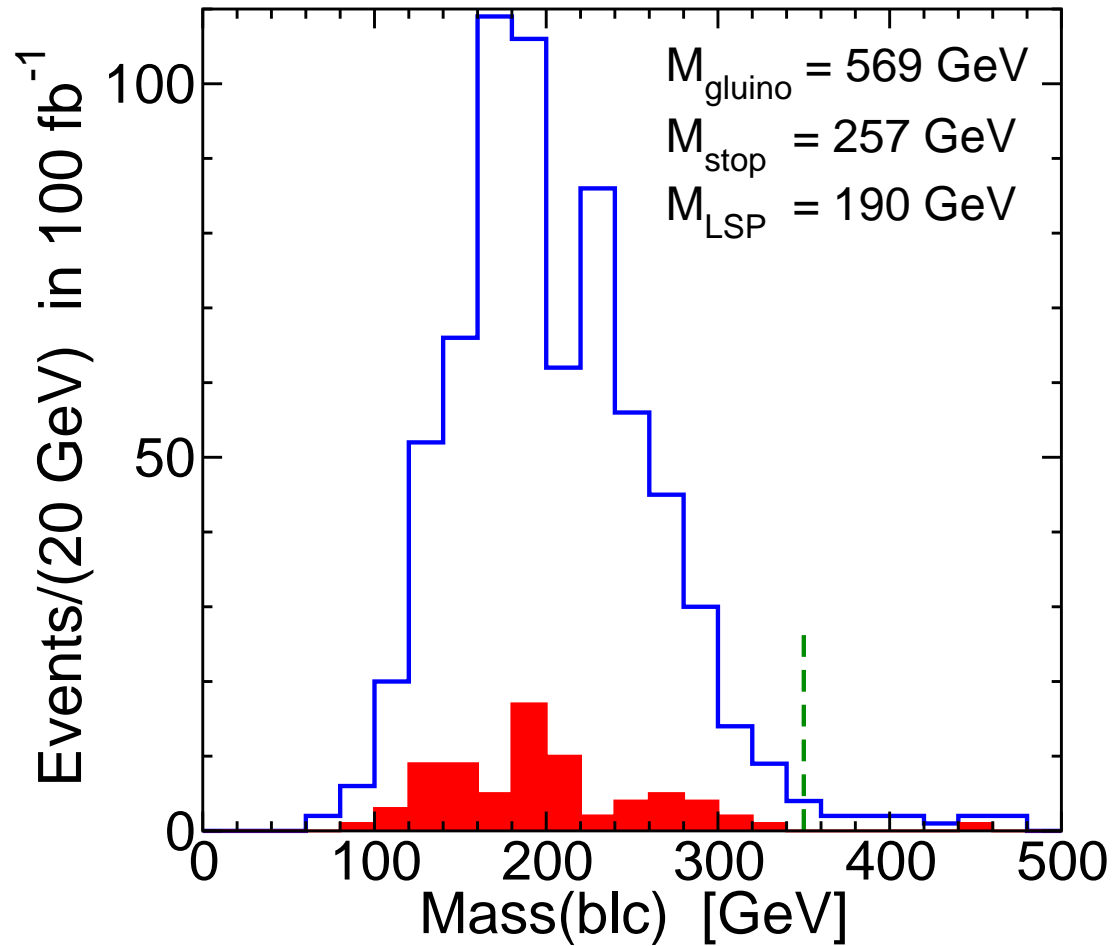

Red part = charm jet also has a heavy flavor tag or soft muon

Same model, but $M(bc)_{\max}$ distribution, with a nominal endpoint of 279 GeV:

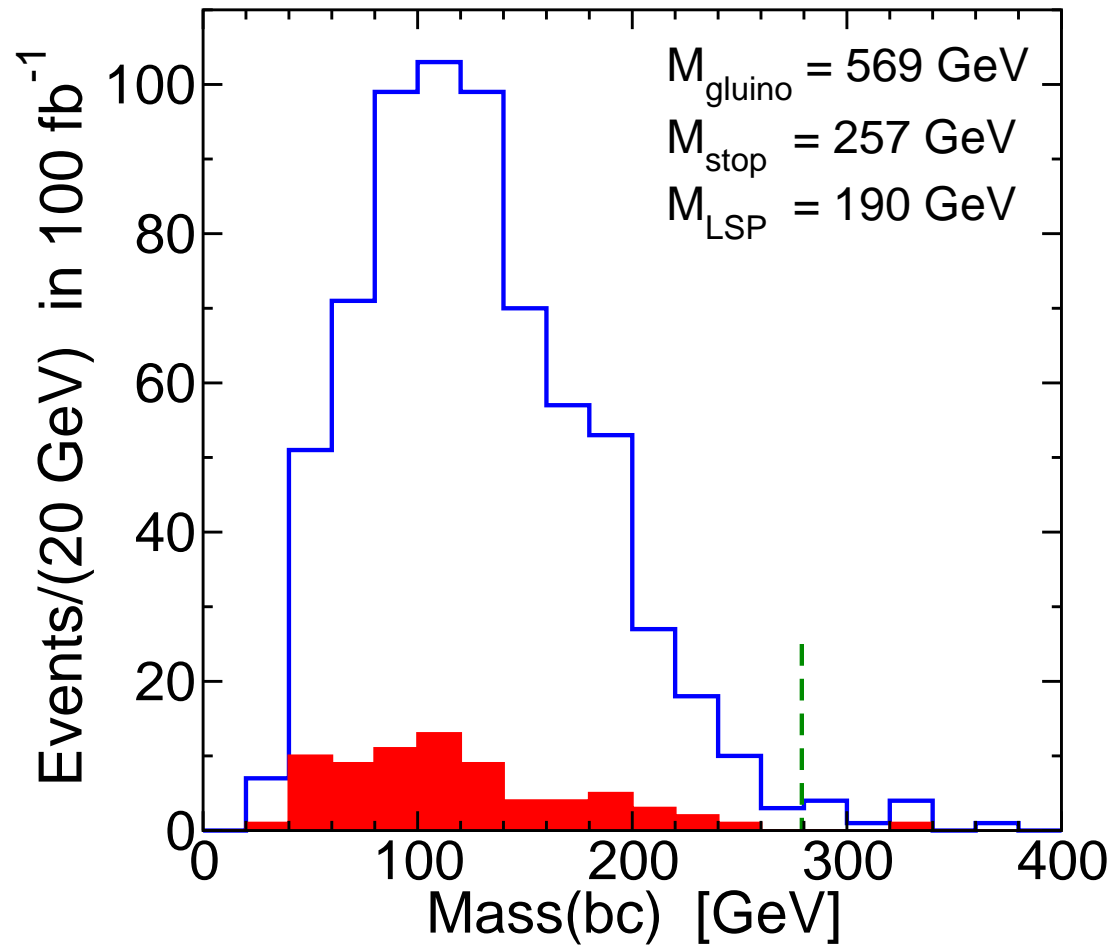

Now, the Bad News. In principle, the endpoints carry information about the gluino, top-squark and LSP masses. But in practice they depend only very weakly on the model!

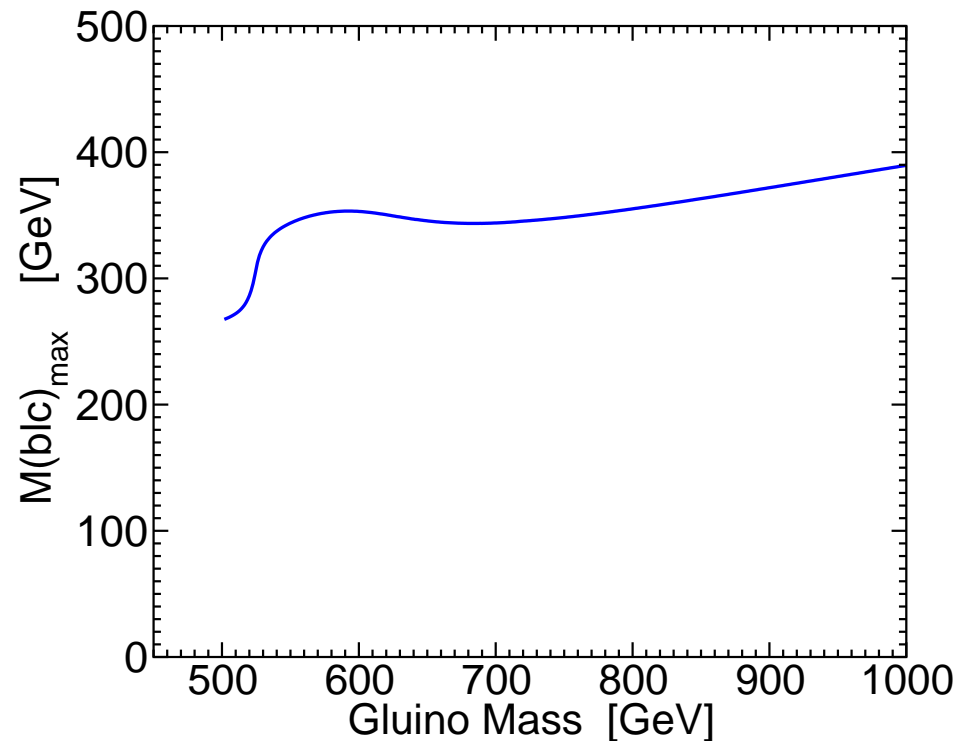

So this will probably provide confirming evidence of the signal's origin, rather than new information about the superpartner masses.

In the classic collider signatures for SUSY,

Invisible LSPs \rightarrow Missing Energy \rightarrow No Mass Peaks

Compressed SUSY provides an exception, because of the long lifetime of \tilde{t}_1 :

Stoponium = $\eta_{\tilde{t}}$ = s-wave $\tilde{t}_1\tilde{t}_1^*$ bound state

Drees and Nojiri 1994 proposed looking for stoponium in

$$pp \rightarrow \eta_{\tilde{t}} \rightarrow \gamma\gamma$$

Stoponium is very narrow, so the width is effectively that of the detector resolution for diphotons, of order 1% at CMS and ATLAS.

Stoponium in Compressed SUSY:

- is always stable enough to form
- Binding energy of $\eta_{\tilde{t}}$ is a few GeV
- Decay width $\Gamma_{\eta_{\tilde{t}}}$ is a few MeV
- $M_{\eta_{\tilde{t}}}$ between about 350 and 750 GeV
- $\text{BR}(\eta_{\tilde{t}} \rightarrow gg)$ dominates (but huge background)
- $\text{BR}(\eta_{\tilde{t}} \rightarrow \gamma\gamma) \approx 0.4\%$

The process

$$pp \rightarrow \eta_{\tilde{t}} \rightarrow \gamma\gamma$$

is clearly NOT a discovery mode for supersymmetry.

Importance is that it will give a uniquely precise measurement of the top-squark mass.

Look for a narrow diphoton mass peak against a smoothly falling background. To be conservative, I count events in a bin of width $0.04M_{\gamma\gamma}$ centered on the putative peak.

The irreducible physics backgrounds at leading order:

$$q\bar{q} \rightarrow \gamma\gamma \quad (\text{tree-level})$$

$$gg \rightarrow \gamma\gamma \quad (\text{1-loop})$$

Backgrounds from fakes are thought to be smaller.

Diphoton backgrounds at LHC, at leading order,
after cuts:

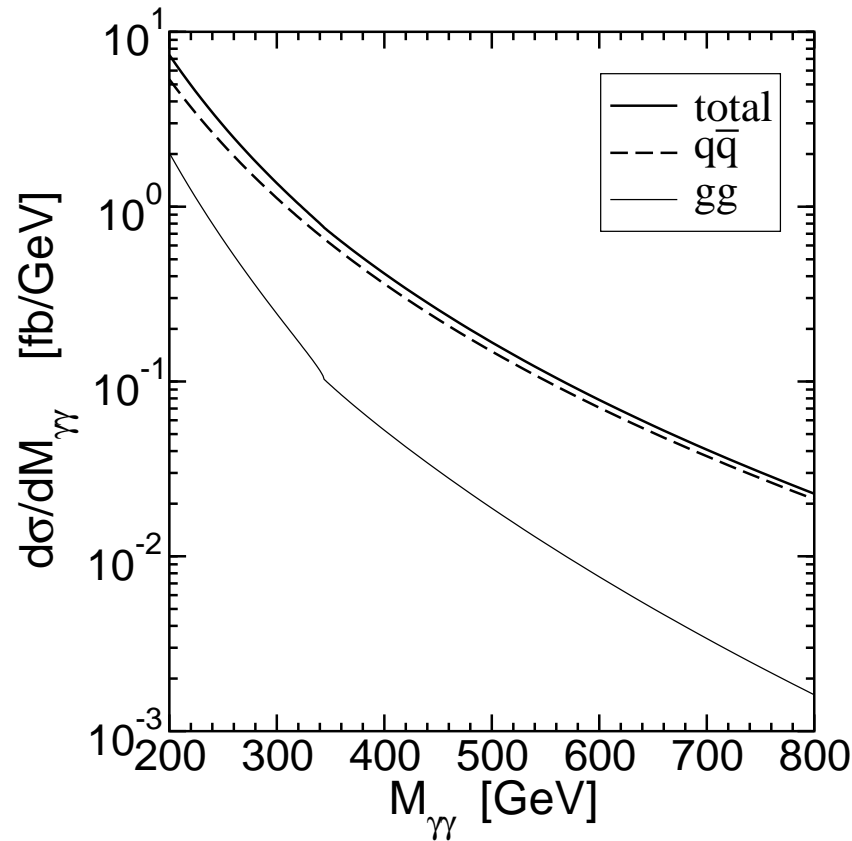

Note: actual background will be obtained from LHC data!

Luminosity needed for expected significances, for two model lines:

$$C_{24} = 0.21, \quad A_0/M_1 = -1$$

$$C_{24} = 0.21, \quad A_0/M_1 = -2$$

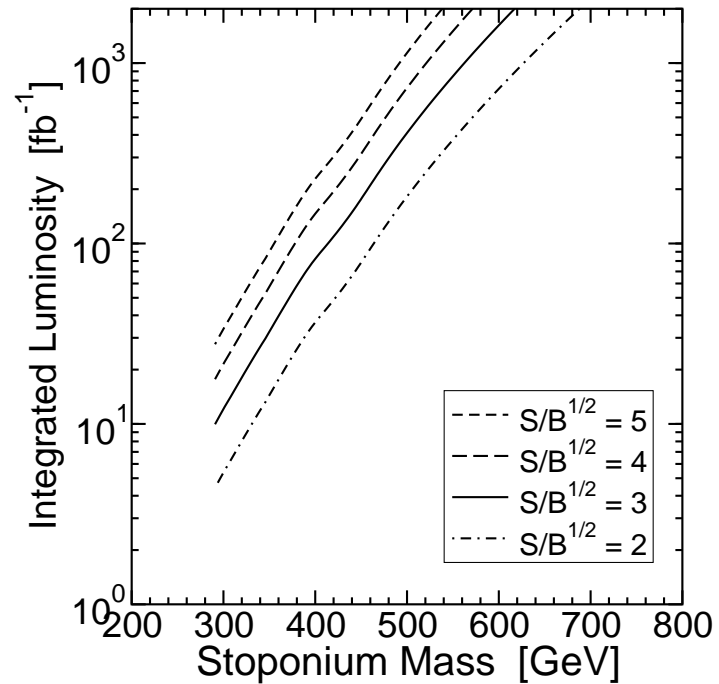
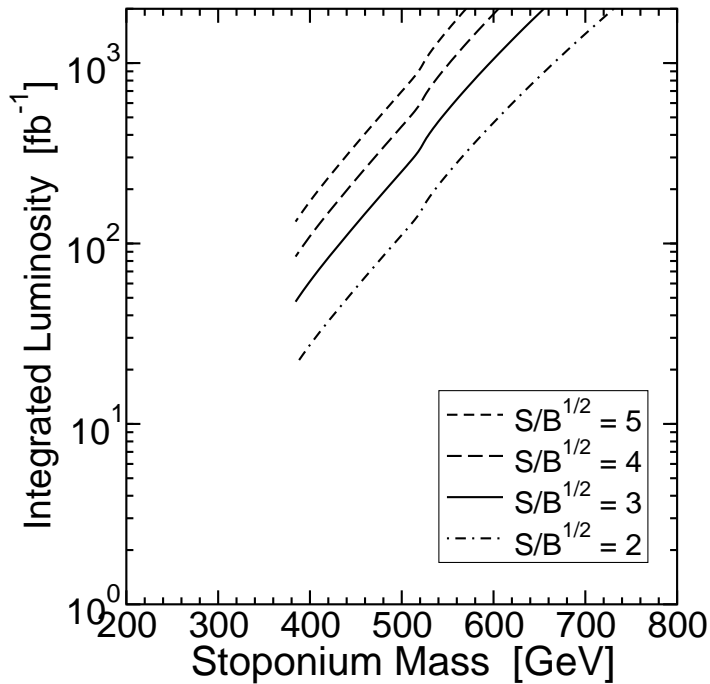

Detectability for $m_{\eta_{\tilde{t}}} = 500$ GeV will require more than 100 fb^{-1} .
 For smaller $m_{\eta_{\tilde{t}}}$, a few $\times 10 \text{ fb}^{-1}$ might do it (if we're lucky).

Compressed SUSY:

- gives a qualitatively distinct way of producing the correct relic abundance of dark matter
- ameliorates the SUSY little hierarchy problem
- has distinctive LHC phenomenology
 - Same-Sign tops + E_T^{miss}
 - no easy dilepton mass edges
 - (typically) **no** information about sleptons, winos, or higgsinos
 - stoponium!

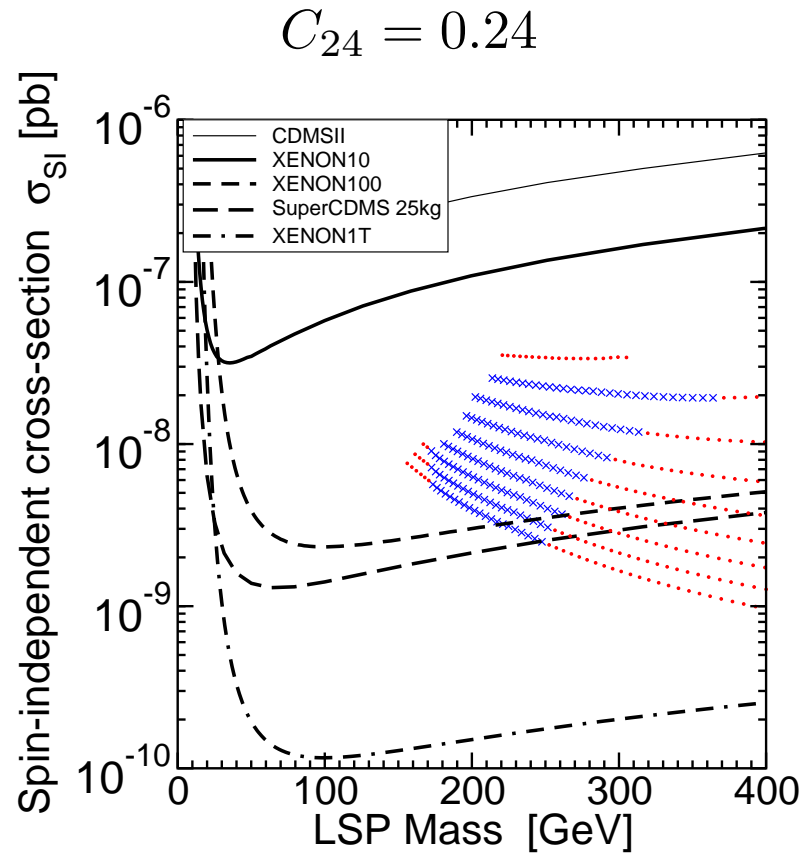
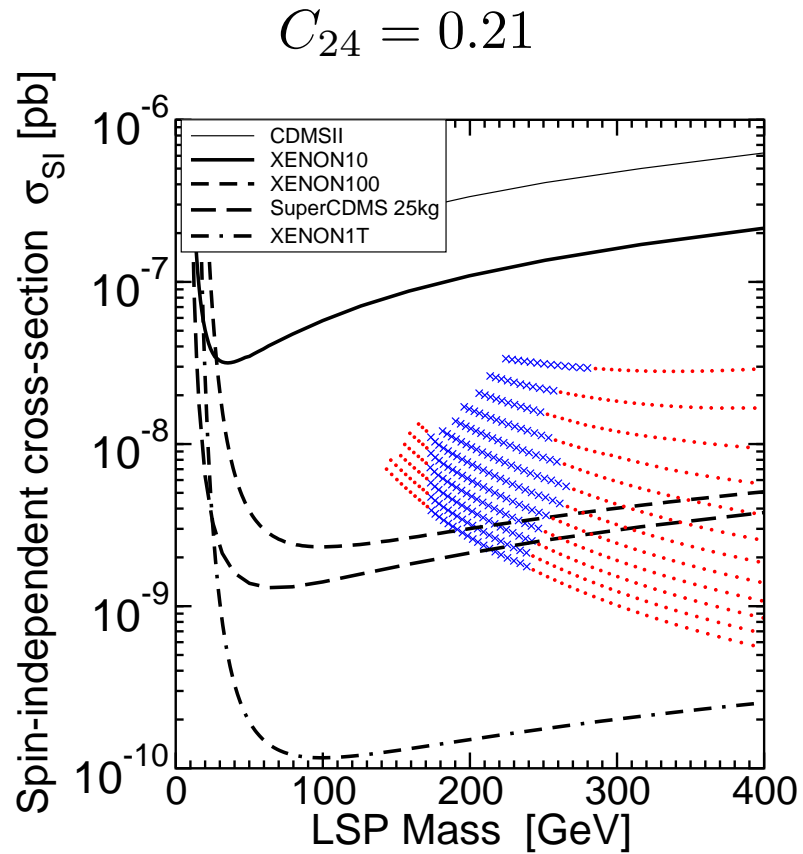

Blue X's = “bulge” annihilation-to-top models,

Red dots = stop co-annihilation models

Present experiments do not constrain the scenario.

Future experiments should provide a definitive test.

The target is here!

In this scenario, superpartners are too heavy to give much hope at the Tevatron.

One can look for the top squark \tilde{t}_1 by:

$$p\bar{p} \rightarrow \tilde{t}_1\tilde{t}_1^* \rightarrow c\bar{c}\tilde{N}_1\tilde{N}_1 \rightarrow c\bar{c} + E_T^{\text{miss}}$$

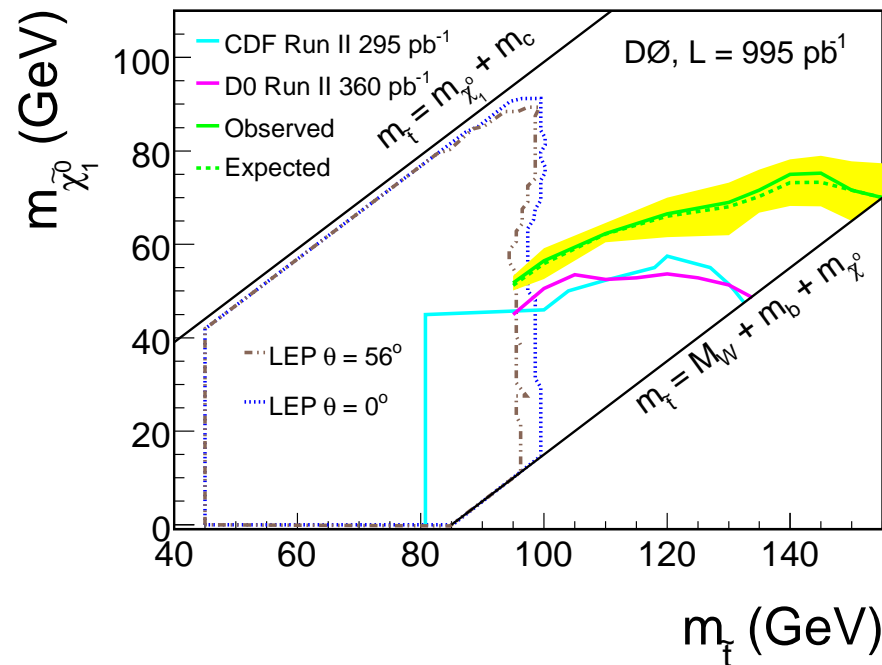

Usual Tevatron signals for SUSY, trileptons, like-sign dileptons, jets + E_T^{miss} , all seem to be very hard or impossible. Not enough events.